



# Schürch Woodwork

## Using veneer hand tools

### Veneer Tape Dispenser

A gum tape dispenser that will take 3/4" wide gum tape is excellent for securing veneer seams together. A manual pull and tear machine which has a brush or sponge that will moisten tape (25 gram weight). It is indispensable for any shop that works with veneer. A sponge in a cup works well for moistening short lengths of tape for smaller projects.

### Veneer Gum Tape

25 to 30 gram (non-perforated) veneer tape that has water activated hide or vegetable glue is ideal for veneering. It is cut to length, moistened with a sponge or with the tape dispenser wetting system, placed over the veneer seam or joint, and smoothed or burnished down with a brush or rag to secure it firmly onto the veneer. It is used for final assembly of veneer joints in decorative veneering, in order to create a single skin or sheet of veneer. Ideally, after the gum tape is applied over the joints, the assembled veneer skin gets placed between two plattens to insure that the moisture from the gum tape does not warp the veneer until it dries. This complete skin will then be glued onto a foundation or core of smooth plywood or MDF, with the gum tape side exposed. After the veneer is glued to the core with a mechanical or vacuum type veneer press, the tape is removed by moistening and peeling it off with a sharpened flexible putty knife, or sanded off the veneer with a belt, stroke or random orbital sander. The best method seems to be first 'scuff sanding' the panel with a 120 grit 4 X 24 belt sander, or block sand with 100 grit in order to start leveling out different thickness of veneer and break through the top layer of gum tape. Next, remove the rest of the gum tape with water and a tape knife. This tape is available in rolls that are 3/4" to 2" wide.

### Tape Brush

An extremely fine (34 gauge wire) brass brush is perfect for burnishing the moist gum tape onto the veneer, but a plastic scrub brush with cotton rag could also work. I find that the fine bristle securely massages the tape into the veneer and wicks the moisture away to some degree.

### Tape Knife

Sharpened and polished with a buffing wheel, a flexible putty knife that facilitates the clean and efficient removal of gum tape after the veneer skin has been glued onto the core or foundation is good to have. First, wet the surface of the tape for one or two minutes, then push or scrape the layers of tape off the surface with the knife. Any glue residue left on the veneer from the gum tape will be removed during the sanding process.

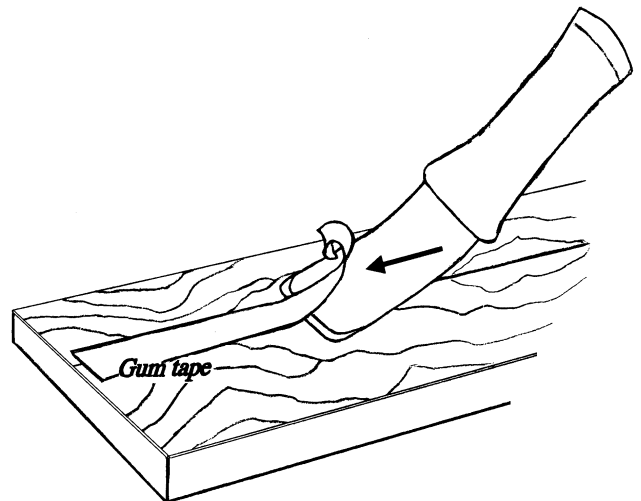

### Veneer Masking Tape

This is low tack blue masking tape. This special tape from 3M (2090) is excellent for assembling veneer seams, decorative patterns and marquetry. It is used to temporarily pull together and hold the seams of the veneer together on the 'glue surface' of the veneer so one can apply the gum tape onto the opposite 'show face', or final exposed

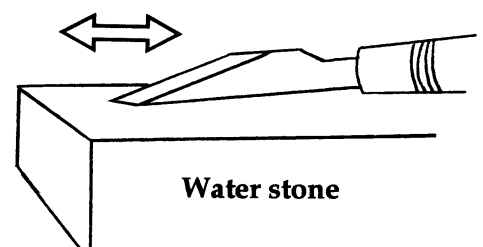

side of the veneer on the panel. It will not leave a residue, tear fibers or be difficult to remove, provided that it is not left out in the sun, exposed to heat, or pressed on with force as in a veneer press. The 3/4" tape has the right amount of elasticity to stretch over a seam and 'draw' the joint together, and 3" wide mask tape is ideal for assembling marquetry. It is removed from the 'glue face' after the gum tape has dried. (about 15 to 30 minutes). It cannot be used to hold the veneer together during the final pressing (with glue) onto the core because will be very difficult to remove from the finished veneer panel.

### Scalpel

A surgical scalpel handle with a high carbon steel blade is very useful for cutting brittle or difficult veneers. Although they are similar to the Exacto #11 type blades, these extremely sharp, higher quality blades cut better, and can be sharpened many times on a water stone before needing to be replaced. The BACK of the blade tip is honed or slightly removed on a water or oil stone to expose a new sharp tip on the blade. The scalpel is mainly used with a straight edge for straight line cutting of veneer.

### Veneer Chisel

A 40 mm Chrome vanadium Double Cherry chisel is ideally suited for delicate veneer work, although many 1 1/2" chisels would do, provided the back is very flat, and is comfortable to hold. It can be used in conjunction with a straight edge for straight seam knife cuts, for free-hand cutting, for assembly of banding or 'filetti' inlay and intricate veneer inlay. It is the main tool used for the cutting of veneer. The chisel is sharpened on a grinding wheel and honed on a 1200 grit flat water stone as you would a normal chisel, paying close attention to keeping the back completely flat on the stone while knocking off the burr created by the honed chisel facet. After it has been sharpened on the stone, polish the edge on a felt wheel with rouge. The outer tip of the chisel that is actually cutting the veneer needs to be ever so slightly rounded by buffing both sides of the tip. The chisel will then draw properly through the veneer, without following the grain and splitting the veneer. Grasping the chisel close to the facet, the first cutting pass needs to be as light as a feather, to score the veneer. This will allow the subsequent passes to follow the path you have established, and to cut through completely on the third or fourth pass. The chisel can inlay, or cut one piece of veneer (scrap) into another. Place the scrap onto the veneer background, score the background using the scrap veneer edge as a fence or guide, and finishing the cuts with the tip of the chisel. If you are working from the glue face and are cutting toward the show face on the background veneer, the inlay will be a perfect fit. This method can be used to remove defects in burls.

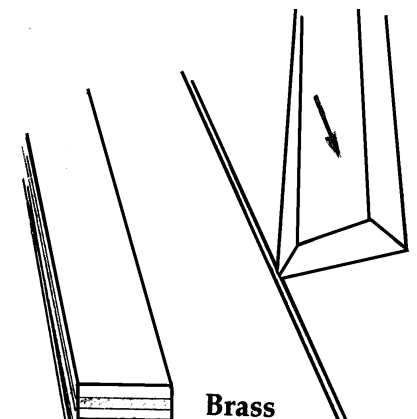
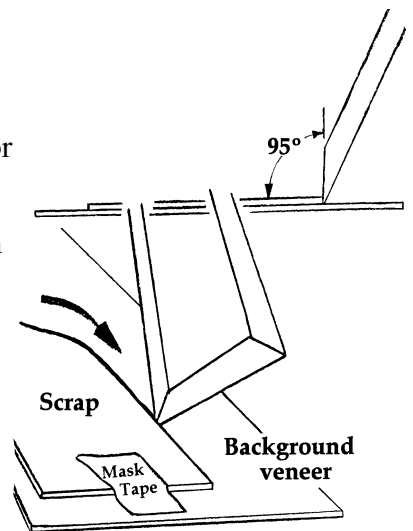
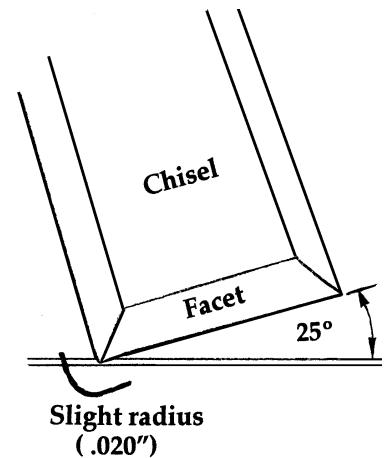

### Straight Edge

A Brass and multi-plywood straight edge for straight line knife cutting or veneer sawing is the best. The brass is ideal for a knifing edge because it will not damage the knife blade that is riding against it, and acts like a lubricant against the hard steel. The 'knife edge' side of the straight edge can be made from 1/8" x 2' brass flat bar and have a bevel on the outer edge. As the chisel facet is run against the brass edge, one can draw the sharpened tip through the veneer, and cut through with three passes. The 'sawing side' of the straight edge can be 3/4" multiply or a separate piece of MDF which will give a good vertical edge on which to guide the veneer saw on. Ideally, a straight edge should be slightly bowed or tensioned so one can hold it down firmly on a piece of veneer with one hand, while cutting or sawing with the other hand, without the straight edge or veneer shifting.

### **Tweezers or Tongs**

A tool for precision handling of veneer inlay is needed for the sand shading process, decorative veneering and marquetry assembly. This particular tool is made using flexible tempered 420 stainless steel with precision ground tips, and is an asset for any shop that handles small components. The tips of the tongs have been engineered to easily scoop, pick up and handle small or flat objects smaller than a grain of sand (or the period in this sentence.). The tips are sharp and can also be used for cutting, parallel slicing, or pairing down material. You can make these yourself, from two hacksaw blades that have the tips sharpened, and are taped together on the handle end.

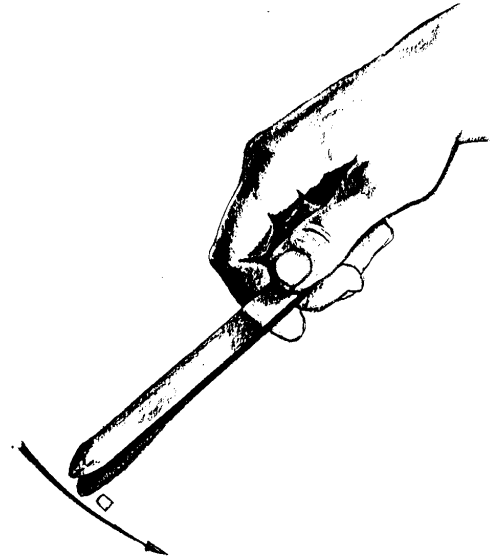

### **Scroll Saw Blades**

#2/0 - .010" thick- 26 to 30 tpi skip tooth German scroll saw blades (12 per pack) are the most durable, finest kerf, for the precise cutting of veneers in packet, or contour cutting of marquetry. They can be used to cut up to 16 layers of veneer at once in a good quality scroll saw such as an older model Powermatic or Delta Milwaukee 'spring top' scroll saw (my favorite). The Eclipse, Excalibur, Dewalt or Delta scroll saw will also work well. The double arm or pivoting arm system that most scrollsaws possess have the blade moving front to back in a slightly orbital fashion and usually have no blade backing guides for precise cutting, but will track well for packet cutting. A momentary 'on/off' foot switch is very useful when using this saw for intricate cutting, changing directions of the cut, and stopping the noise when the blade brakes.

### **Veneer Nails**

These are small 23 gauge x 3/4" long headless wire nails for clench nailing or fixing veneer layers together into a sandwich type package prior to scroll saw cutting. They are nailed through the entire packet, and the nails bent over on both sides of the packet to 'clench' the layers of veneer together. 'Packet cutting' is commonly used in decorative veneering and marquetry. The small hole created in the veneer by the nail will virtually disappear after the skin is glued to the core. Micro pin nail gun uses such nails, and is an excellent tool for production marquetry.

### **Veneer Saw**

The veneer saw is a popular tool for cutting veneers and is widely available through many catalogs. It is primarily used for roughing out and cutting through many layers of veneer at a time, although it can be used for fine precise straight cuts on individual layers of veneer. For this finer use of the veneer saw, it needs to be sharpened properly. The blade should be removed from the handle, and held firmly in a saw vise, clamped close to the teeth. Using a small fine 60 degree triangular file held 90 degrees to the blade and canted at the same angle as the teeth, start sharpening the teeth from the front of the saw, moving toward the back teeth. Usually two light pushes with the file held steadily in the hand will be enough. After this is complete, the saw teeth need to be beveled to a point with a fine flat file. This is accomplished by securing the blade on the edge of a workbench, and flat angle filing the teeth to a point, filing on the handle side of the blade. The angle of the flat file should be about 15 to 25 degrees. Care must be taken to file the saw teeth only to a sharp point and no further. Filing too much will create a flat top on the point of the tooth, and the saw will not cut properly. After this flat filing is done, remove the burr on the saw back that rides against the straight edge with a 1000 grit waterstone, and the saw is ready for use.

## Sharpening a Veneer Saw

### 1- Filing

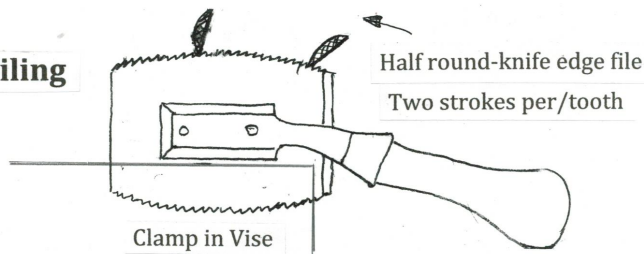

### 2- Serrated edge bevel

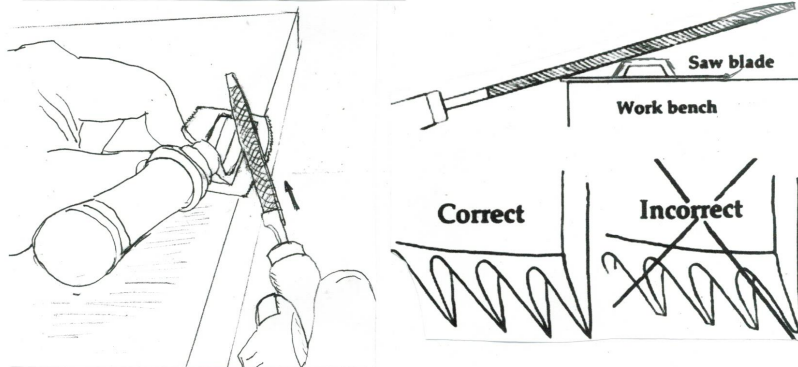

### 3- Removing Burr

1000 or 2500 Grit  
Water Stone

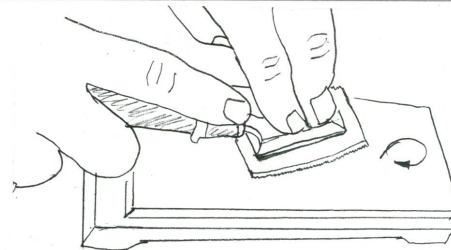

### A few points to remember.

- Always cut the veneer and inlays from the glue side of the skin toward the show face. The V shaped cuts created by the knives will be toward the core, and the clean tight joints will be visible. You can fill gaps and big open joints from the back with slivers of veneer, or glue and sawdust. Differing thickness of veneer can be compensated for by placing a layer of visqueen and canvas over the veneer during glue up in the press. Unibond or urea formaldehyde and White or PVA glues are excellent for veneering. Gaps can be filled after the glue up with Famowood putty, and one can use any number of finishes such as lacquer, oil, shellac, or varnish that will look good, depending on the final use of the veneer work. You will be very surprised at how easy it is to create professional results.

It is my hope that I have been able to introduce you to the practical and beautiful art of decorative veneering, instill some confidence and inspire students to try this craft on their own projects in their own shops. I will continue with my role as a teacher, by completing the three part video series project, continuing teaching one, five and ten day seminars, will sponsor interns and continue to offer 2 and 4 year apprenticeships to qualified individuals striving to perfect the fine art of fine furniture building and design, decorative veneering, inlay and marquetry.